



## PSSu E F 2DI 60-R

**PILZ**  
THE SPIRIT OF SAFETY

- ▶ Decentralised system PSSuniversal I/O

This document is a translation of the original document.

All rights to this documentation are reserved by Pilz GmbH & Co. KG. Copies may be made for internal purposes. Suggestions and comments for improving this documentation will be gratefully received.

Source code from third-party manufacturers or open source software has been used for some components. The relevant licence information is available on the Internet on the Pilz homepage.

Pilz®, PIT®, PMI®, PNOZ®, Primo®, PSEN®, PSS®, PVIS®, SafetyBUS p®, SafetyEYE®, SafetyNET p®, the spirit of safety® are registered and protected trademarks of Pilz GmbH & Co. KG in some countries.



SD means Secure Digital

<b>Section 1</b>	<b>Introduction</b>	<b>5</b>
	1.1 Validity of documentation	5
	1.1.1 Retaining the documentation	5
	1.1.2 Terminology: System environment A and B	5
	1.2 Definition of symbols	6
<b>Section 2</b>	<b>Overview</b>	<b>7</b>
	2.1 Module structure	7
	2.2 Module features	7
	2.3 Front view	8
<b>Section 3</b>	<b>Safety</b>	<b>10</b>
	3.1 Intended use	10
	3.2 Safety regulations	10
	3.2.1 Use of qualified personnel	10
	3.2.2 Warranty and liability	11
	3.2.3 Disposal	11
<b>Section 4</b>	<b>Function description</b>	<b>12</b>
	4.1 Block diagram	12
	4.2 Module features	12
	4.2.1 Functions	12
	4.2.2 Integrated protection mechanisms	12
	4.2.3 Reaction times	13
	4.3 Configuration	13
	4.3.1 PSSu assignment in system environment B	13
<b>Section 5</b>	<b>Installation</b>	<b>14</b>
	5.1 General installation guidelines	14
	5.1.1 Dimensions	14
	5.2 Installing the base module	15
	5.3 Inserting and removing an electronic module	16
	5.3.1 Inserting an electronic module	17
	5.3.2 Removing an electronic module	18
	5.3.3 Changing an electronic module during operation	18
<b>Section 6</b>	<b>Wiring</b>	<b>19</b>
	6.1 General wiring guidelines	19
	6.1.1 Mechanical connection of the base modules	19
	6.2 Terminal configuration	21
	6.3 Connecting the module	22
<b>Section 7</b>	<b>Operation</b>	<b>24</b>
	7.1 Messages	24
	7.2 Display elements	24
	7.2.1 Display elements for module diagnostics	24
	7.2.2 Display elements for input status	25

---

<b>Section 8</b>	<b>Technical details</b>	<b>26</b>
8.1	Safety characteristic data	28
<hr/>		
<b>Section 9</b>	<b>Order reference</b>	<b>29</b>
9.1	Product	29
9.2	Accessories	29

---

# 1 Introduction

## 1.1 Validity of documentation

This documentation is valid for the product type PSSu E F 2DI 60-R. It is valid until new documentation is published.

This operating manual explains the function and operation, describes the installation and provides guidelines on how to connect the product.

### 1.1.1 Retaining the documentation

This documentation is intended for instruction and should be retained for future reference.

### 1.1.2 Terminology: System environment A and B

The PSSu system can be used in two different system environments. The module's application area is described in the chapter "Intended Use" of the manual.

The distinction is made between

- ▶ PSSu in system environment A
- ▶ PSSu in system environment B

The distinction is based on the application area of the PSSu system.

PSSu in system environment A may be used in the

- ▶ Decentralised system PSSu I/O
- ▶ **Not** in the automation system PSS 4000

PSSu in system environment B may be used in the

- ▶ Automation system PSS 4000, e.g. with
  - Decentralised system PSSu I/O with SafetyNET p
  - Control system PSSu PLC
  - Control system PSSu multi

The module PSSu E F 2DI 60-R is exclusively for use in system environment B (automation system PSS 4000).

## 1.2 Definition of symbols

Information that is particularly important is identified as follows:



### **DANGER!**

This warning must be heeded! It warns of a hazardous situation that poses an immediate threat of serious injury and death and indicates preventive measures that can be taken.



### **WARNING!**

This warning must be heeded! It warns of a hazardous situation that could lead to serious injury and death and indicates preventive measures that can be taken.



### **CAUTION!**

This refers to a hazard that can lead to a less serious or minor injury plus material damage, and also provides information on preventive measures that can be taken.



### **NOTICE**

This describes a situation in which the product or devices could be damaged and also provides information on preventive measures that can be taken. It also highlights areas within the text that are of particular importance.



### **INFORMATION**

This gives advice on applications and provides information on special features.

## 2 Overview

### 2.1 Module structure

A module consists of

- ▶ Electronic module and
- ▶ Base module with
  - Screw terminals or
  - Cage clamp terminals

The base modules are the carrier units for the electronic modules and are used to connect the field wiring. The electronic modules are inserted on to the base modules and determine the module's function.

Details of the base modules that can be used are available in the chapter entitled "Intended Use".

### 2.2 Module features

The product has the following features:

- ▶ 2 galvanically isolated digital inputs
- ▶ LEDs for:
  - Switch status of each input
  - Module error
- ▶ For failsafe applications in system environment B (automation system PSS 4000)

## 2.3 Front view

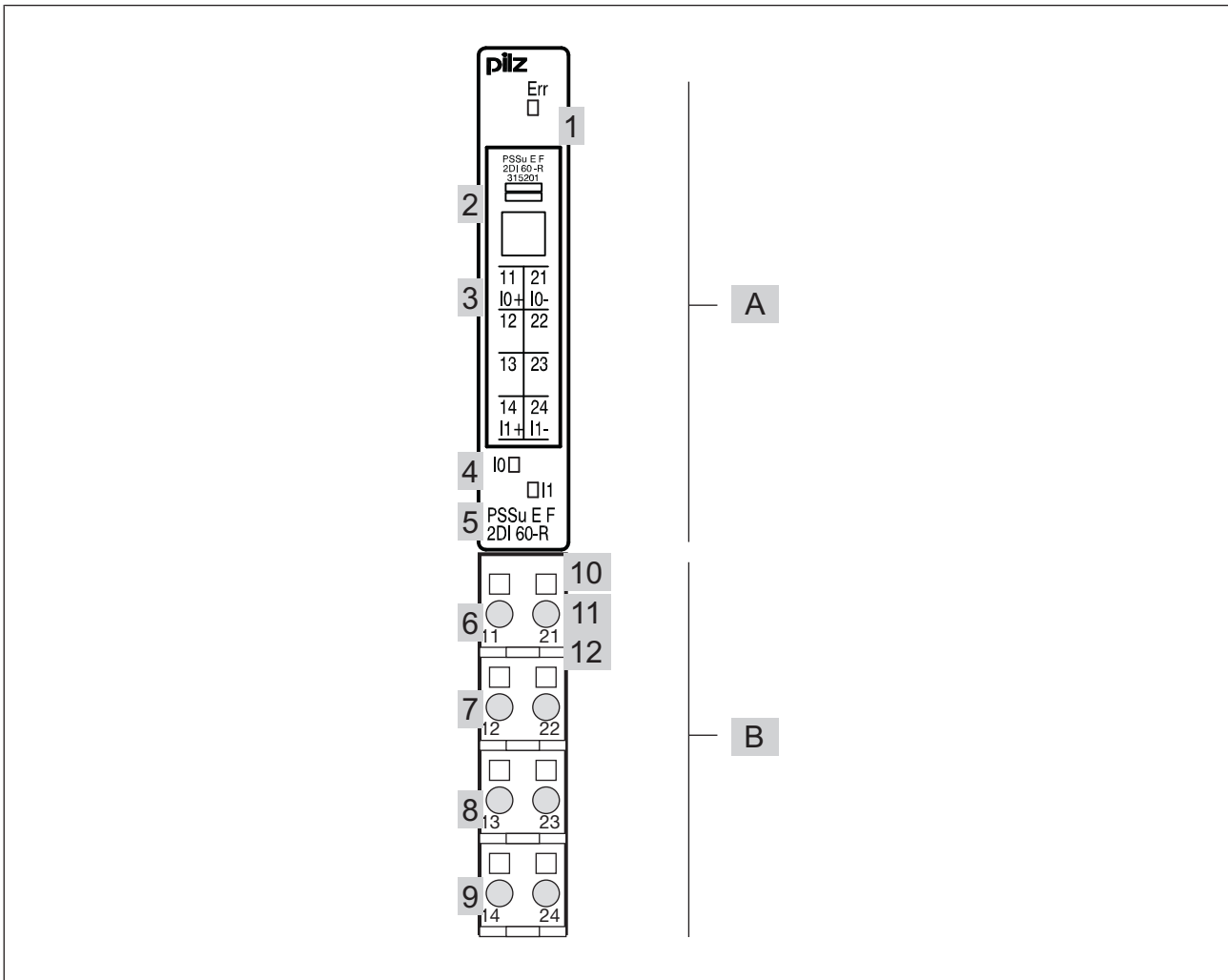

### Legend:

- ▶ A: Electronic module
- ▶ B: Base module
- ▶ 1: LED for module diagnostics
- ▶ 2: Labelling strip with:
  - Name of electronic module
  - Order Number
  - Serial number
  - Hardware version number
  - 2D code
- ▶ 3: Labelling strip for the terminal configuration on the base module
- ▶ 4: Status LEDs
- ▶ 5: Name of electronic module
- ▶ 6: Connection level 1
- ▶ 7: Connection level 2

- ▶ 8: Connection level 3
- ▶ 9: Connection level 4
- ▶ 10: Square mounting holes (connection levels 1, 2, 3 and 4)
  - With screw to loosen/tighten the screw terminal on base modules with screw terminals
  - With mechanism to operate the cage clamp on base modules with cage clamp terminals
- ▶ 11: Round connection holes (connection levels 1, 2, 3 and 4) for connecting the signal lines
- ▶ 12: Mounting slot for colour marker to label the connection level (connection levels 1, 2, 3 and 4)

## 3 Safety

### 3.1 Intended use

The module may be used for failsafe applications in system environment B (automation system PSS 4000).

The module meets the requirements of EN IEC 61508 up to SIL 3.

The failsafe inputs are not classified in accordance with the standard IEC 61131-2.

The module PSSu E F 2DI 60-R-R is suitable for use where there are increased environmental requirements demanded by railway applications (see Technical details).

Intended use includes making the electrical installation EMC-compliant. Please refer to the guidelines stated in the "PSSuniversal Installation Manual". The module is designed for use in an industrial environment. It is not suitable for use in a domestic environment, as this can lead to interference.

The following is deemed improper use in particular:

- ▶ Any component, technical or electrical modification to the module
- ▶ Use of the module outside the areas described in this manual
- ▶ Any use of the module that is not in accordance with the technical details.



#### INFORMATION

The module is supported by PAS4000 from version 1.5.0. We recommend that you always use the latest version (download from [www.pilz.com](http://www.pilz.com)).

The PSSu E F 2DI 60-R module may be used in conjunction with the following base modules:

- ▶ PSSu BP 1/8 S-T
- ▶ PSSu BP 1/8 C-T
- ▶ PSSu BP 1/12 S-T
- ▶ PSSu BP 1/12 C-T
- ▶ PSSu BP-C1 1/12 S-T
- ▶ PSSu BP-C1 1/12 C-T

### 3.2 Safety regulations

#### 3.2.1 Use of qualified personnel

The products may only be assembled, installed, programmed, commissioned, operated, maintained and decommissioned by competent persons.

A competent person is a qualified and knowledgeable person who, because of their training, experience and current professional activity, has the specialist knowledge required. To be able to inspect, assess and operate devices, systems and machines, the person has to be informed of the state of the art and the applicable national, European and international laws, directives and standards.

It is the company's responsibility only to employ personnel who

- ▶ Are familiar with the basic regulations concerning health and safety / accident prevention,
- ▶ Have read and understood the information provided in this description under "Safety"
- ▶ Have a good knowledge of the generic and specialist standards applicable to the specific application.

### 3.2.2 **Warranty and liability**

All claims to warranty and liability will be rendered invalid if

- ▶ The product was used contrary to the purpose for which it is intended
- ▶ Damage can be attributed to not having followed the guidelines in the manual
- ▶ Operating personnel are not suitably qualified
- ▶ Any type of modification has been made (e.g. exchanging components on the PCB boards, soldering work etc.).

### 3.2.3 **Disposal**

- ▶ In safety-related applications, please comply with the mission time  $T_M$  in the safety-related characteristic data.
- ▶ When decommissioning, please comply with local regulations regarding the disposal of electronic devices (e.g. Electrical and Electronic Equipment Act).

## 4 Function description

### 4.1 Block diagram

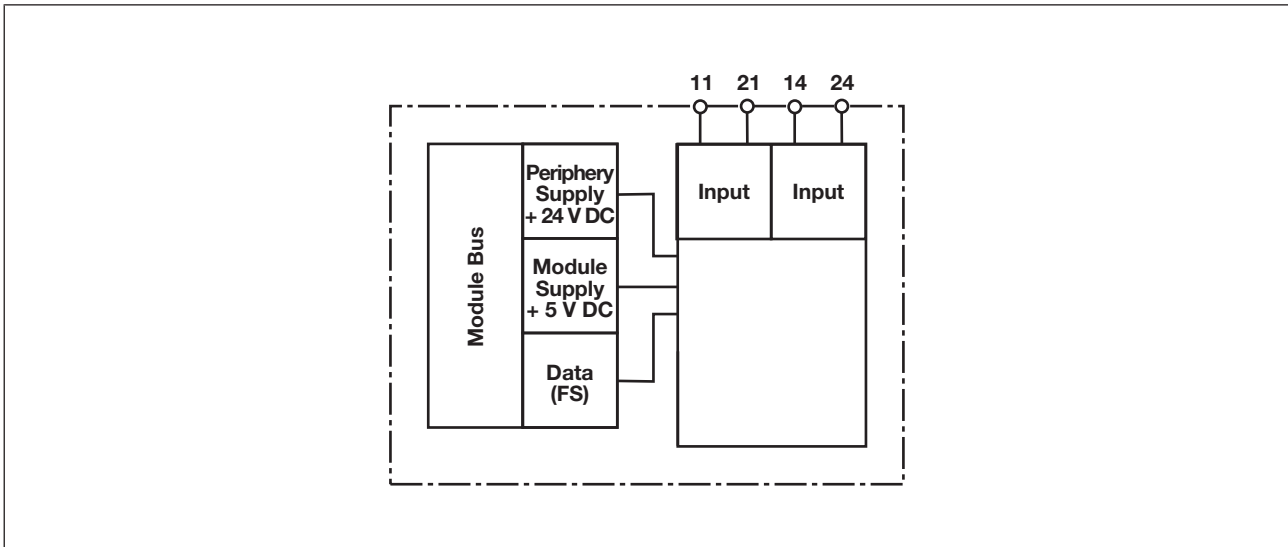

### 4.2 Module features

#### 4.2.1 Functions

Module supply

- ▶ The module supply provides the module with voltage.

Inputs

- ▶ The status of the inputs is signalled to the head module via the module bus.
- ▶ The module's inputs are galvanically isolated from each other and from the module supply.
- ▶ The inputs have input filters.

#### 4.2.2 Integrated protection mechanisms

When the PSSu E F PS1(-T) or PSSu E F PS2(-T)(-R) is used to supply the system, the module supply is buffered for 20 ms if the supply voltage is interrupted.

The module provides the following diagnostic data:

- ▶ Start-up error
- ▶ Configuration error
- ▶ FS communication error
- ▶ Bus termination error
- ▶ Temperature error: too warm
- ▶ Input error

### 4.2.3 Reaction times

Information on the reaction times of the inputs can be found in the System Description "Automation system PSS 4000".

## 4.3 Configuration

### 4.3.1 PSSu assignment in system environment B

Data access is via pre-defined I/O data types:

I/O data name	I/O data type	I/O data element	Key
I0(11,21),I1(14,24)	FS_I_DI	Data: SAFEBOOL	Input data I0 ... I1

## 5 Installation

### 5.1 General installation guidelines

Please also refer to the PSSuniversal Installation Manual.



**NOTICE**

Damage due to electrostatic discharge!

Electrostatic discharge can damage components. Ensure against discharge before touching the product, e.g. by touching an earthed, conductive surface or by wearing an earthed armband.

#### 5.1.1 Dimensions

Base modules with four connection levels:

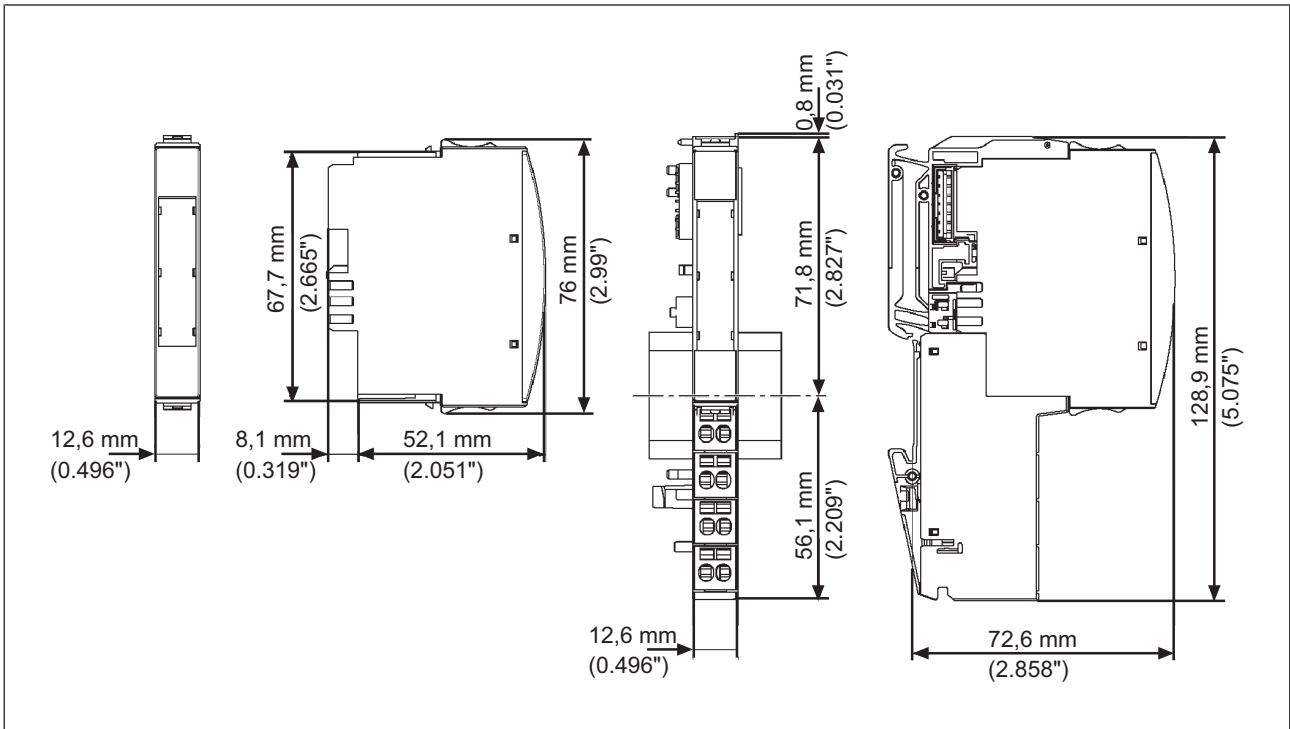

Base modules with six connection levels:

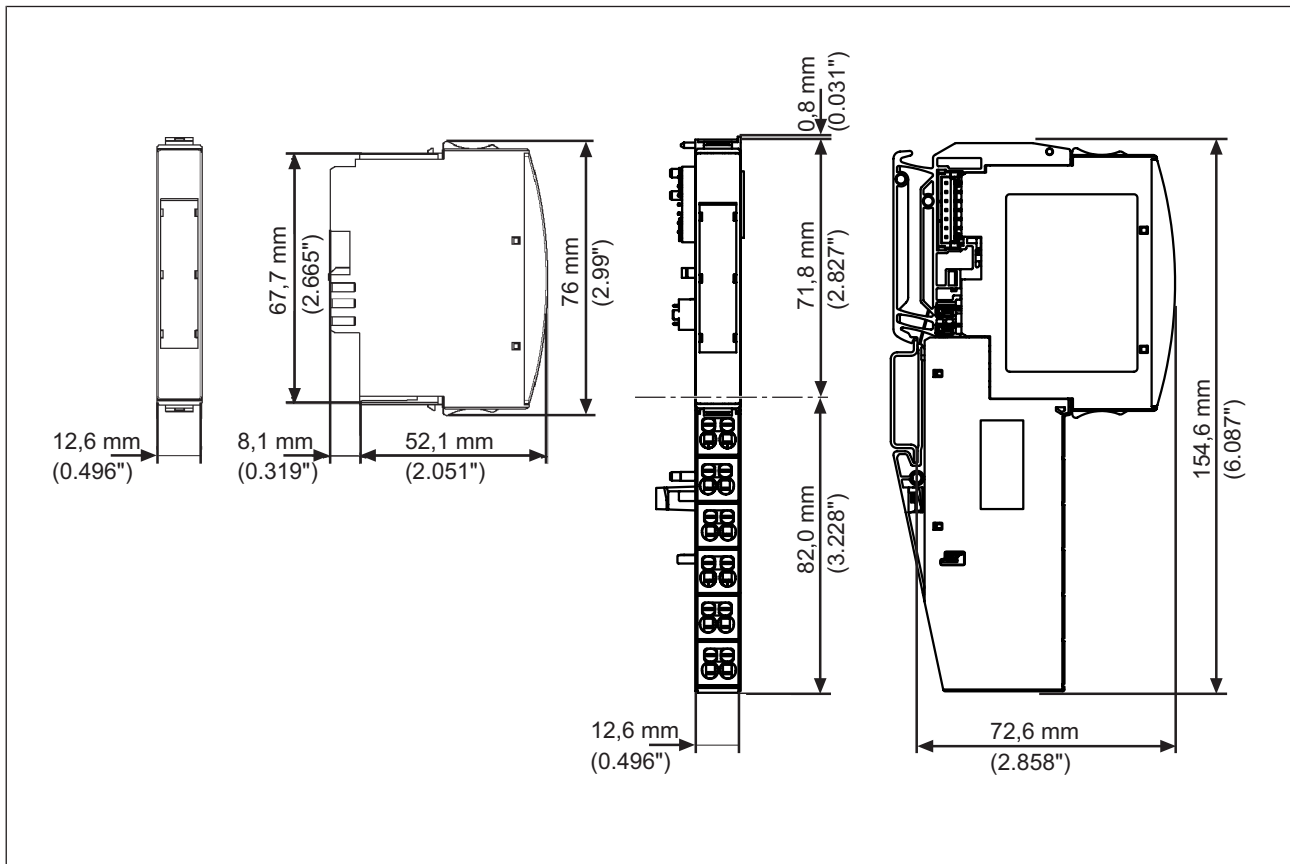

## 5.2 Installing the base module

Prerequisite:

- ▶ The head module must be installed.
- ▶ If the head module does not have an integrated power supply, a supply voltage module must be installed to the right of the head module.

Please note:

- ▶ For mechanical reasons it is not possible to mix base modules with screw terminals and base modules with cage clamp terminals.
- ▶ All contacts should be protected from contamination.
- ▶ The mechanics of the base modules are designed for 50 plug in/out cycles.

Procedure:

- ▶ We recommend that you wire up the base modules before inserting the electronic modules.
- ▶ Slot the groove on the base module on to the mounting rail from below [1].
- ▶ Push the base module back [2] until you hear it lock into position.
- ▶ On the mounting rail, slide the base module to the left until you hear the two lateral mounting hooks on the adjacent module lock into position [3].

Schematic representation:

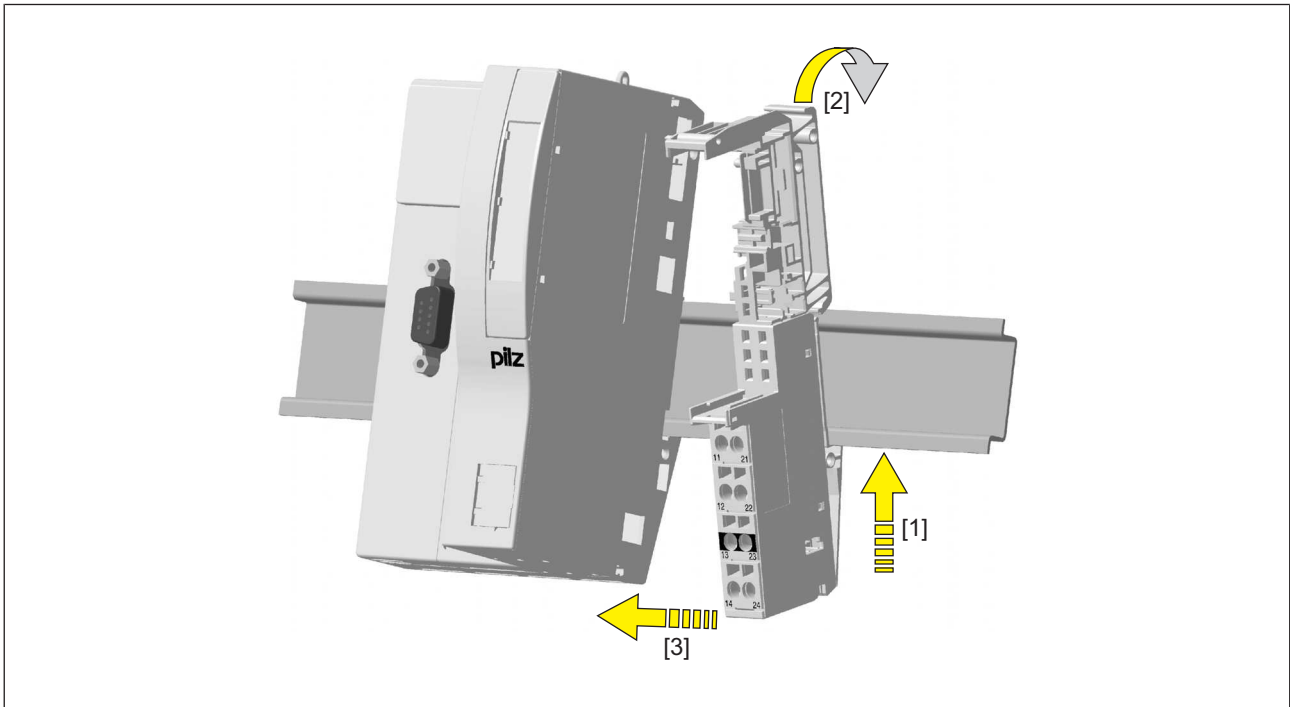

### 5.3 Inserting and removing an electronic module

Please note:

- ▶ Only insert on to base modules that are already installed.
- ▶ Preferably these base modules should be ready wired.
- ▶ Electronic modules with outputs may only be inserted and removed when the load is switched off. Unforeseeable error reactions may be triggered if modules are inserted and removed under load.
- ▶ When an electronic module is plugged into a base module for the first time, one part of the coding element remains on the electronic module, while its counterpart is fixed on to the base module. This is how the base module is coded.
- ▶ The mechanics of the electronic modules are designed for 50 plug in/out cycles.

### 5.3.1 Inserting an electronic module

Procedure:

- ▶ The electronic module must audibly lock into position [1].
- ▶ Mark the electronic module using the labelling strips [2].

Schematic representation:

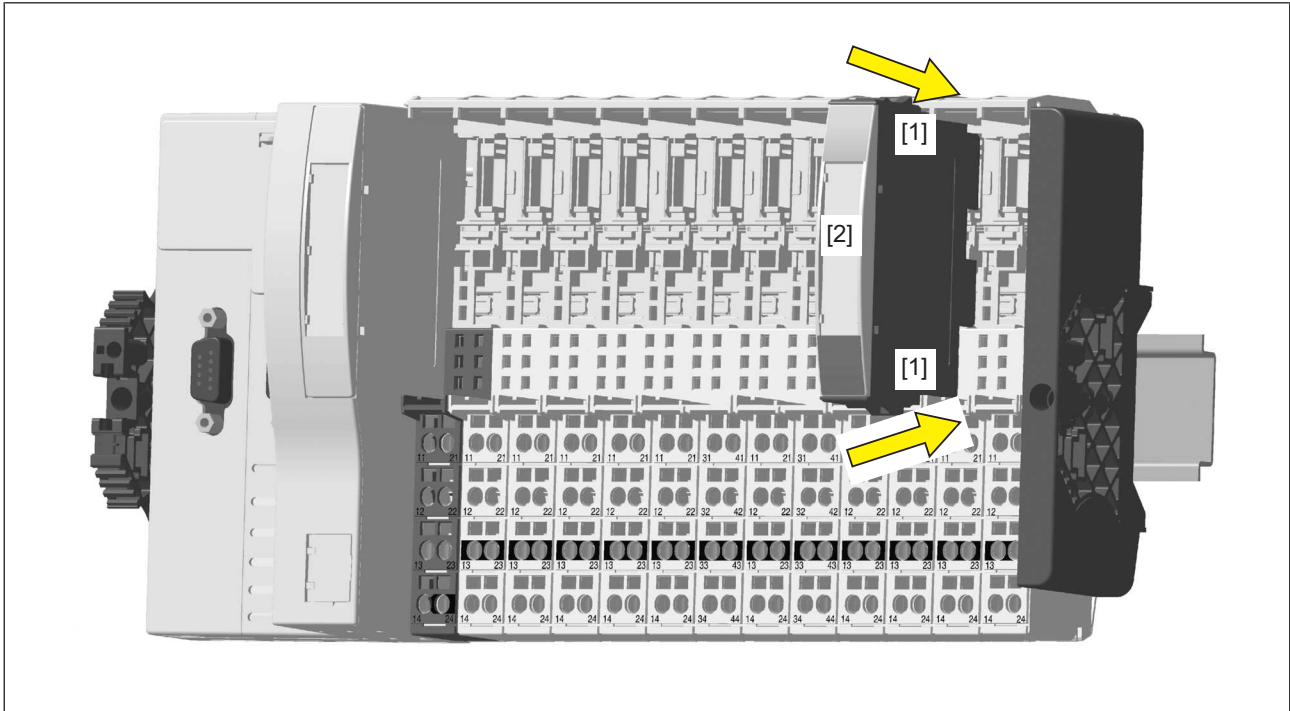

### 5.3.2 Removing an electronic module

Procedure:

- ▶ Press the locking mechanisms [1] together simultaneously.
- ▶ Pull out the electronic module [2].

Schematic representation:

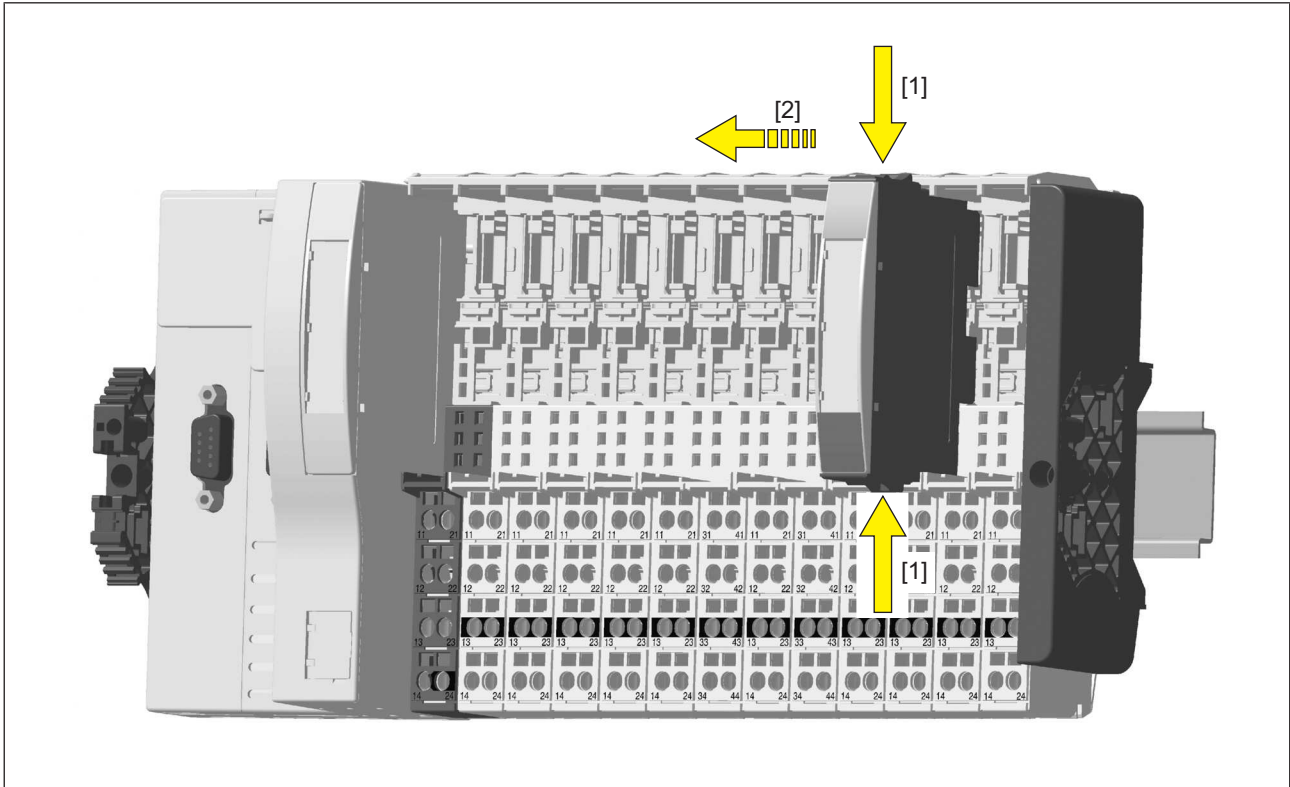

### 5.3.3 Changing an electronic module during operation

It is possible to change an electronic module during operation. The configuration data is retained when a module is changed.

Effects:

- ▶ System environment A:
  - In the event of a potential FS communication error, the FS section of the PSSu system and all relevant I/O-Groups (SafetyBUS p) switch to a STOP condition.
- ▶ System environment B:
  - All FS hardware outputs on the PSSu system switch to a safe condition.
  - The substitute values are used for the modules' FS outputs, with Valid Bits = FALSE.



#### CAUTION!

Sparking can cause interference and errors!

Only change the module when the load is switched off!

## 6 Wiring

### 6.1 General wiring guidelines

Please note:

- ▶ Appropriate wiring must be used to exclude short circuits between the inputs or to a supply line!
- ▶ Signal lines do not have to be shielded.
- ▶ Use copper wiring.

#### 6.1.1 Mechanical connection of the base modules

Procedure:

- ▶ Use a flat blade screwdriver (DIN 5264-A)!

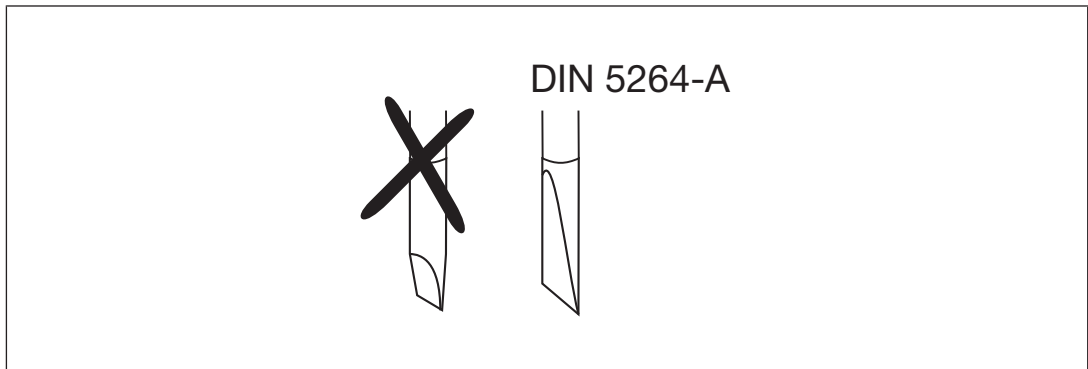

- ▶ Strip the wire back 8 mm.
- ▶ If necessary, label the connection level with a colour marker [3].
- ▶ Base module with screw terminals:
  - Use a screwdriver to loosen the screw on the screw terminal [1]
  - Insert the stripped cable into the round fixing hole [2], as far as it will go.
  - Tighten up the screw on the screw terminal.
  - Check that the cable is firmly seated.
- ▶ Base module with cage clamp terminals:
  - Insert the screwdriver [4] into the square hole [1].
  - Insert the stripped cable into the round fixing hole [2], as far as it will go [5].
  - Pull out the screwdriver [6].
  - Check that the cable is firmly seated.

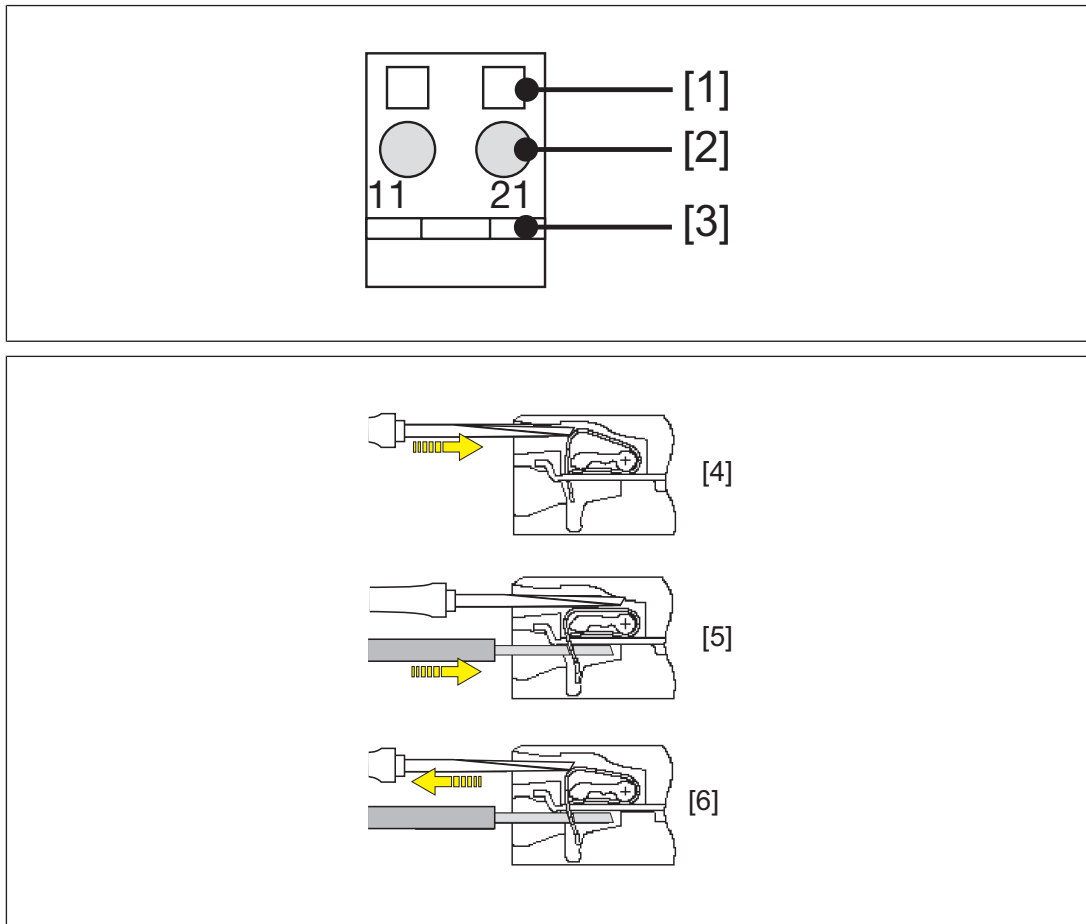

Please note:

- ▶ The minimum cable cross section for field connection terminals on the base modules is 0.14 mm<sup>2</sup> (AWG26).
- ▶ The maximum cable cross section for field connection terminals is:
  - Digital inputs: 1.5 mm<sup>2</sup> (AWG16)
  - Digital outputs: 2.0 mm<sup>2</sup> (AWG14)
  - Inputs/outputs on the counter modules: 1.5 mm<sup>2</sup> (AWG16)
  - Analogue inputs/outputs: 1.5 mm<sup>2</sup> (AWG16)
  - Communication cables: 1.5 mm<sup>2</sup> (AWG16)
  - Test pulse outputs: 1.5 mm<sup>2</sup> (AWG16)
  - Power supply: 2.5 mm<sup>2</sup> (AWG12)
  - Functional earth: 2.5 mm<sup>2</sup> (AWG12)
- ▶ On base modules with screw terminals:
  - If you use a multi-strand cable to connect the I/Os, it is recommended that you use ferrules conforming to Parts 1 and 2 of DIN 46228, 0.14 ... 1.5 mm<sup>2</sup>, Form A or C, although this is not essential. To crimp the ferrules you can use crimp pliers (crimp form A or C) conforming to EN 60947-1, such as the PZ 1.5 or PZ 6.5 from Weidmüller, for example.
  - Maximum torque setting: 0.8 Nm

- ▶ Use copper wiring.

## 6.2 Terminal configuration

Base module	Terminal configuration	
Screw terminals: PSSu BP 1/8 S-T  Cage clamp terminals: PSSu BP 1/8 C-T	Without C-rail:  11: Input I0+  21: Input I0-  14: Input I1+  24: Input I1-	
	With C-rail:  11: Input I0+  21: Input I0-  12-22: n.c.  13-23: C-rail supply (13-23-16-26 linked within the base module)  14: Input I1+  24: Input I1-  15-25: n.c.  16-26: C-rail supply (13-23-16-26 linked within the base module)	

- ▶ n.c. = not connected

### 6.3 Connecting the module

Input circuit	Single-channel input device	Dual-channel input device
<p>Input device with homogenous channels</p>		

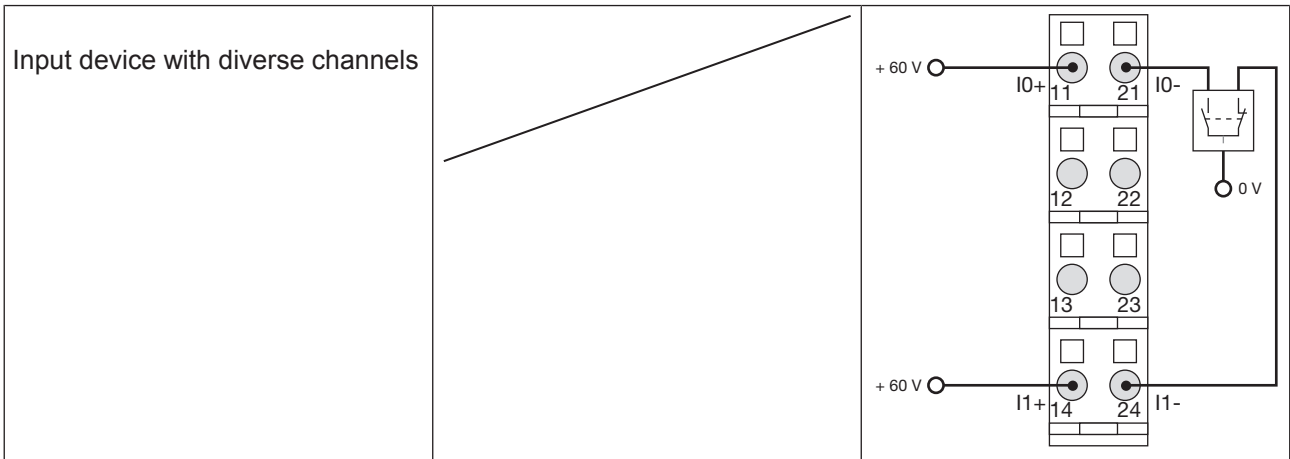

## 7 Operation

### 7.1 Messages



A module error is displayed via the "Err" LED, signalled to the head module and then entered in the head module's diagnostic log.

The module can detect the following errors:

Module error	Statement	Remedy
Start-up error	Error as the PSSu system starts up	Change faulty module.
Configuration error	Incorrect module type configured.	The configured hardware registry does not match the actual hardware registry.
FS communication error	Error during FS communication	Change faulty module.
Bus termination error	There is no terminating plate or there is a bad contact with the module bus.	Install a terminating plate with integrated end bracket or insert the base modules together correctly.
Temperature error: too warm	Ambient temperature too high: Error stack entry/diagnostic log entry	Ensure there is sufficient ventilation in the control cabinet or prevent overload.
Input error	Error during the cyclical input test. Possible cause: Input defective.	Change faulty module.



### 7.2 Display elements

#### Legend

-  LED on
-  LED off

#### 7.2.1 Display elements for module diagnostics

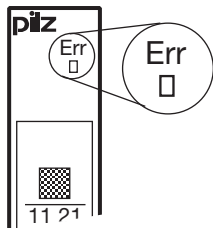
The module has an LED for displaying module errors ("Err" LED).

	LED			Meaning
	Name	Colour	Status	
	Err	---		No error
	Red		Module error	

### 7.2.2 Display elements for input status

Each input is assigned an LED for displaying the input status (LEDs "11", "21", "14" and "24").

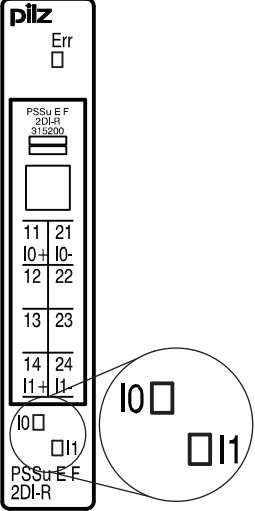
	LED			Meaning		
	Designation	Colour	Status	Signal	Input	Terminal
	I0	---	●	0 signal	I0 (Input 1)	11/21
		Green	☀	1 signal		
	I1	---	●	0 signal	I1 (Input 2)	14/24
		Green	☀	1 signal		

## 8 Technical details

<b>General</b>	
Approvals	<b>CE, TÜV, cULus Listed</b>
Application range	<b>Failsafe</b>
Module's device code	<b>0A01h</b>
Application in system environment B	
From FS firmware version, head modules	<b>1.5.0</b>
<b>Electrical data</b>	
Internal supply voltage (module supply)	
Module's power consumption	<b>0,12 W</b>
Max. power dissipation of module	<b>1,5 W</b>
<b>Inputs</b>	
Number	<b>2</b>
Voltage at inputs	<b>24 - 72 V</b>
Input current range	<b>1,5 - 8,5 mA</b>
Min. threshold voltage when signal changes from "1" to "0"	<b>5 V</b>
Max. threshold voltage when signal changes from "0" to "1"	<b>19,2 V</b>
Typ. processing time of the input tProclM	<b>2 ms</b>
Max. processing time of the input tProclM in the event of an error	<b>4 ms</b>
Potential isolation between input and internal module bus voltage	<b>yes</b>
<b>Environmental data</b>	
Application site	
In accordance with the standard	<b>EN 50125-3</b>
Application site	<b>Track area (1 m - 3 m)</b>
In accordance with the standard	<b>EN 61373</b>
Application site	<b>Category 1, Class A + B</b>
Climatic suitability	<b>EN 50125-1, EN 50125-3, EN 50155, EN 60068-2-1, EN 60068-2-14, EN 60068-2-2</b>
Ambient temperature	
In accordance with the standard	<b>EN 50155</b>
Temperature range	<b>-40 - 70 °C</b>
In accordance with the standard	<b>EN 50125-1</b>
Temperature range	<b>-40 ... +70 °C</b>
In accordance with the standard	<b>EN 50125-3</b>
Temperature range	<b>-40 ... +70 °C</b>
Storage temperature	
In accordance with the standard	<b>EN 60068-2-1/-2</b>
Temperature range	<b>-40 - 70 °C</b>
Climatic suitability	
In accordance with the standard	<b>EN 60068-2-78</b>
Humidity	<b>93 % r. h. at 40 °C</b>

<b>Environmental data</b>	
Condensation during operation	<b>Short-term</b>
Max. operating height above sea level	<b>2000 m</b>
EMC	<b>EN 61000-4-2, EN 61000-4-3, EN 61000-4-4, EN 61000-4-5, EN 61000-4-6, EN 61000-6-2, EN 61000-6-4</b>
Vibration	
In accordance with the standard	<b>EN 50125-3</b>
Frequency	<b>5 - 2000 Hz</b>
Acceleration	<b>0,23g</b>
Broadband noise	
In accordance with the standard	<b>EN 61373</b>
Frequency	<b>5 - 150 Hz</b>
Acceleration	<b>0,79 g RMS</b>
Shock stress	
In accordance with the standard	<b>EN 50125-3</b>
Number of shocks	<b>20</b>
Acceleration	<b>2g</b>
Duration	<b>11 ms</b>
In accordance with the standard	<b>EN 61373</b>
Number of shocks	<b>20</b>
Acceleration	<b>5g</b>
Duration	<b>30 ms</b>
Supply interruptions	
In accordance with the standard	<b>EN 50155</b>
Airgap creepage	
In accordance with the standard	<b>EN 50124-1</b>
Overvoltage category	<b>OV2</b>
Pollution degree	<b>PD2</b>
Protection type	
In accordance with the standard	<b>EN 60529</b>
Housing	<b>IP20</b>
Terminals	<b>IP20</b>
Mounting area (e.g. control cabinet)	<b>IP51</b>
<b>Mechanical data</b>	
Material	
Bottom	<b>PC</b>
Front	<b>PC</b>
Coding	<b>PA</b>
Mounting type	<b>plug-in</b>
Dimensions	
Height	<b>76 mm</b>
Width	<b>12,6 mm</b>
Depth	<b>60,2 mm</b>
Weight	<b>45 g</b>

**Mechanical data**

Mechanical coding

Type	N
Colour	Yellow

Where standards are undated, the 2009-10 latest editions shall apply.

**8.1 Safety characteristic data**



**NOTICE**

You must comply with the safety-related characteristic data in order to achieve the required safety level for your plant/machine.

Operating Mode	EN ISO 13849-1: 2015 PL	EN ISO 13849-1: 2015 Category	EN 62061 SIL CL	EN 62061 PFH <sub>D</sub> [1/h]	IEC 61511 SIL	IEC 61511 PFD	EN ISO 13849-1: 2015 T <sub>M</sub> [year]
1-channel	PL d	Cat. 2	SIL CL 2	8,18E-09	SIL 2	6,88E-04	20
2-channel	PL e	Cat. 4	SIL CL 3	1,38E-09	SIL 3	1,95E-05	20

All the units used within a safety function must be considered when calculating the safety characteristic data.



**INFORMATION**

A safety function's SIL/PL values are **not** identical to the SIL/PL values of the units that are used and may be different. We recommend that you use the PAScal software tool to calculate the safety function's SIL/PL values.

## 9 Order reference

### 9.1 Product

Product type	Features	Order no.
PSSu E F 2DI 60-R	Electronic module, R-type	315 201

### 9.2 Accessories

#### Base modules

Product type	Features	Order no.
PSSu BP 1/8 S	Base module without C-rail with screw terminals	312 600
PSSu BP 1/8 S-T	Base module without C-rail with screw terminals, T-type	314 600
PSSu BP 1/8 C	Base module without C-rail with cage clamp terminals	312 601
PSSu BP 1/8 C-T	Base module without C-rail with cage clamp terminals, T-type	314 601
PSSu BP 1/12 S	Base module without C-rail with screw terminals	312 618
PSSu BP 1/12 S-T	Base module without C-rail with screw terminals, T-type	314 618
PSSu BP 1/12 C	Base module without C-rail with cage clamp terminals	312 619
PSSu BP 1/12 C-T	Base module without C-rail with cage clamp terminals, T-type	314 619
PSSu BP-C1 1/12 S	Base module with C-rail and screw terminals	312 622
PSSu BP-C1 1/12 S-T	Base module with C-rail and screw terminals, T-type	314 622
PSSu BP-C1 1/12 C	Base module with C-rail and cage clamp terminals	312 623
PSSu BP-C1 1/12 C-T	Base module with C-rail and cage clamp terminals, T-type	314 623